

Clarke®

WOODWORKER



210MM MITRE SAW

MODEL NO: CMS210B

PART NO: 6461520

OPERATION & MAINTENANCE INSTRUCTIONS

UK
CA | CE



ORIGINAL INSTRUCTIONS

GC0422

INTRODUCTION

Thank you for purchasing this CLARKE Mitre Saw.

Before attempting to use this product, please read this manual thoroughly and follow the instructions carefully. In doing so you will ensure the safety of yourself and that of others around you, and you can look forward to your purchase giving you long and satisfactory service.

Mitre saws are intended to cut wood or wood-like products, they cannot be used with abrasive cut-off wheels for cutting ferrous material such as bars, rods, studs, etc

IMPORTANT

Please pay particular attention to all sections of this user guide that display warning symbols and notices.



WARNING: THIS IS A WARNING SYMBOL. THIS SYMBOL IS USED THROUGHOUT THE USER GUIDE WHENEVER THERE IS A RISK OF PERSONAL INJURY. ENSURE THAT THESE WARNINGS ARE READ AND UNDERSTOOD AT ALL TIMES.

The work piece must have a minimum height of 3mm and a minimum width of 10mm. Make sure that the workpiece is always secured with the work clamping device.

GUARANTEE

This product is guaranteed against faulty manufacture for a period of 12 months from the date of purchase. Please keep your receipt which will be required as proof of purchase.

This guarantee is invalid if the product is found to have been abused or tampered with in any way, or not used for the purpose for which it was intended.

Faulty goods should be returned to their place of purchase, no product can be returned to us without prior permission.

This guarantee does not affect your statutory rights.

SAFETY WARNINGS

WORK AREA

1. **Keep the work area clean and well lit.** Cluttered and dark areas invite accidents.
2. **DO NOT operate power tools in explosive atmospheres, such as in the presence of flammable liquids, gases or dust.** Power tools create sparks which may ignite the dust or fumes.
3. **Keep children and bystanders away while operating a power tool.** Distractions can cause you to lose control.

ELECTRICAL SAFETY

1. **Power tool plugs must match the outlet. NEVER modify the plug in any way. DO NOT use adapter plugs with earthed (grounded) power tools.** Unmodified plugs & matching outlets will reduce the risk of electric shock.
2. **DO NOT expose power tools to rain or wet conditions.** Water entering a power tool will increase the risk of electric shock.
3. **DO NOT abuse the power cable. NEVER use it for carrying, pulling or unplugging the power tool. Keep the power cable away from heat, oil, sharp edges or moving parts.** Damaged or entangled cables increase the risk of electric shock.
4. **When operating a power tool outdoors, use an extension cable suitable for outdoor use.** Use of a cable suitable for outdoor use reduces the risk of electric shock.
5. **If operating the power tool in a damp location is unavoidable, use a residual current device (RCD) protected supply.**

PERSONAL SAFETY

1. **Stay alert, watch what you are doing and use common sense when operating a power tool.** DO NOT use a power tool while you are tired or under the influence of drugs, alcohol or medication. A moment of inattention while operating power tools may result in personal injury.
2. **Use safety equipment. Always wear eye protection.** Safety equipment such as dust mask, non-skid safety shoes, hard hat, or hearing protection used for appropriate conditions will reduce personal injuries.
3. **Avoid accidental starting.** Ensure the switch is in the off position before plugging in. Carrying power tools with your finger on the switch or plugging in power tools that have the switch on invites accidents.
4. **Remove any wrench before turning the power tool on.** A wrench left attached to a rotating part may result in personal injury.

5. **DO NOT overreach.** Keep proper footing and balance at all times. This enables better control of the power tool in unexpected situations.
6. **Dress properly.** DO NOT wear loose clothing or jewellery. Keep your hair, clothing and gloves away from moving parts. Loose clothes, jewellery or long hair can be caught in moving parts.
7. A laser beam can cause serious eye injury. DO NOT look into the laser outlet.

POWER TOOL USE AND CARE

1. **DO NOT force the power tool.** Use the correct accessories for your application. The correct power tool will do the job better and safer at the rate which it was designed.
2. **DO NOT use the power tool if the switch does not turn it on and off.** Any power tool that cannot be controlled with the switch is dangerous and must be repaired.
3. **Disconnect the plug from the power source before changing accessories, or storing power tools.** Such preventive safety measures reduce the risk of starting the power tool accidentally.
4. **Store idle tools out of the reach of children and do not allow persons unfamiliar with the power tool or these instructions to operate it.** Power tools are dangerous in the hands of untrained users.
5. **Maintain power tools.** Check for misalignment or binding of moving parts, breakage of parts and any other condition that may affect the power tool's operation. If damaged, have the power tool repaired before use. Many accidents are caused by poorly maintained power tools.
6. **Use the power tool and accessories in accordance with these instructions and in the manner intended, taking into account the working conditions and the work to be performed.** Use of the power tool for operations different from intended could result in a hazardous situation.

ADDITIONAL SAFETY RULES FOR MITRE SAWS

1. Use clamps to support the workpiece whenever possible. If supporting the workpiece by hand, you must always keep your hand at least 100 mm from either side of the saw blade. DO NOT use this saw to cut pieces that are too small to be securely clamped or held by hand. If your hand is placed too close to the saw blade there is an increased risk of injury from blade contact.
2. The workpiece must be stationary and clamped or held against both the fence and the table.

3. **DO NOT** feed the workpiece into the blade or cut "freehand" in any way. Unrestrained or moving workpieces could be thrown at high speeds, causing injury.
4. **NEVER** cross your hand over the intended line of cutting either in front or behind the saw blade. Supporting the workpiece "cross handed" i.e. holding the workpiece to the right of the saw blade with your left hand or vice versa is very dangerous.
5. **DO NOT** reach behind the fence with either hand closer than 100 mm from either side of the saw blade, to remove wood scraps, or for any other reason while the blade is spinning. The proximity of the spinning saw blade to your hand may not be obvious and you may be seriously injured.
6. Inspect your workpiece before cutting. If the workpiece is bowed or warped, clamp it with the outside bowed face toward the fence. ALWAYS make certain that there is no gap between the workpiece, fence and table along the line of the cut. Bent or warped workpieces can twist or shift and may cause binding on the spinning saw blade while cutting. There should be no nails or foreign objects in the workpiece.
7. **DO NOT** use the saw until the table is clear of all tools, wood scraps, etc., except for the workpiece. Small debris or loose pieces of wood or other objects that contact the revolving blade can be thrown with high speed.
8. Cut only one workpiece at a time. Stacked multiple workpieces cannot be adequately clamped or braced and may bind on the blade or shift during cutting.
9. Ensure the mitre saw is mounted or placed on a level, firm work surface before use. A level and firm work surface reduces the risk of the mitre saw becoming unstable.
10. Plan your work. Every time you change the bevel or mitre angle setting, make sure the adjustable fence is set correctly to support the workpiece and will not interfere with the blade or the guarding system. Without turning the tool "ON" and with no workpiece on the table, move the saw blade through a complete simulated cut to assure there will be no interference or danger of cutting the fence.
11. Provide adequate support such as table extensions, saw horses, etc. for a workpiece that is wider or longer than the table top. Workpieces longer or wider than the mitre saw table can tip if not securely supported. If the cut-off piece or workpiece tips, it can lift the lower guard or be thrown by the spinning blade.
12. **DO NOT** use another person as a substitute for a table extension or additional support. Unstable support for the workpiece can cause the blade to bind or the workpiece to shift during the cutting operation pulling you and the helper into the spinning blade.

13. The cut-off piece must not be jammed or pressed by any means against the spinning saw blade. If confined, i.e. using length stops, the cut-off piece could get wedged against the blade and thrown violently.
14. **ALWAYS** use a clamp or a fixture designed to properly support round material such as rods or tubing. Rods have a tendency to roll while being cut, causing the blade to "bite" and pull the work with your hand into the blade.
15. Let the blade reach full speed before contacting the workpiece. This will reduce the risk of the workpiece being thrown.
16. If the workpiece or blade becomes jammed, turn the mitre saw off. Wait for all moving parts to stop and disconnect the plug from the power source. Then work to free the jammed material.
17. After finishing the cut, release the switch, hold the saw head down and wait for the blade to stop before removing the cut-off piece. Reaching with your hand near the coasting blade is dangerous.
18. Hold the handle firmly when making an incomplete cut or when releasing the switch before the saw head is completely in the down position. The resistance of the saw may cause the saw head to be suddenly pulled downward.

SAFETY FOR THE HANDLING OF SAW BLADES

1. Check the condition of the blade before using the saw.
2. **DO NOT** use damaged or deformed saw blades.
3. **ONLY** use saw blades recommended by the manufacturer.
4. Saw blades designed to cut wood and similar materials must comply with EN 847-1.
5. **DO NOT** use saw blades made of high-speed alloy steel (HSS steel). **ONLY** use replacement blades from your CLARKE dealer.
6. Observe the saw blade direction of rotation.
7. Clean any grease, oil and water off of the clamping surfaces.
8. **ONLY** use the saw blade supplied for cutting wood, never for the cutting of metals.
9. **ONLY** use blades with diameters shown by the markings on the saw.
10. Replace damaged or worn saw blades immediately.
11. If the saw blade overheats, stop the machine. Allow the saw blade to cool down before using the machine again.

LASER SAFETY



CAUTION: METHODS OTHER THAN THOSE SPECIFIED HERE CAN RESULT IN DANGEROUS RADIATION EXPOSURE.

1. **DO NOT** look directly into the laser beam with unprotected eyes.
2. **NEVER** look into the path of the beam.
3. **NEVER** point the laser beam towards reflecting surfaces and persons or animals. Even a laser beam with a low output can cause damage to the eyes.
4. **NEVER** open the laser module. Unexpected exposure to the beam can occur.
5. The laser may not be replaced with a different type of laser.
6. Repairs of the laser may only be carried out by the laser manufacturer or an authorised representative.







RESIDUAL RISKS

1. Despite all precautions having been met, some non-obvious residual risks may still remain.
2. Residual risks can be minimised if the safety warnings are observed along with the whole of the operating instructions.
3. **DO NOT** load the machine unnecessarily. Excessive pressure when sawing will quickly damage the saw blade which results in reduced output of the machine in the processing and in cut precision.
4. When cutting plastic material, please always use clamps: the parts being cut must always be fixed between the clamps.
5. Avoid accidental starting of the machine: the operating button may not be pressed when inserting the plug in an outlet.
6. Hands must never enter the cutting zone when the machine is in operation.



WARNING: THIS ELECTRIC TOOL GENERATES AN ELECTROMAGNETIC FIELD DURING USE. THIS FIELD CAN IMPAIR ACTIVE OR PASSIVE MEDICAL IMPLANTS UNDER CERTAIN CONDITIONS. IN ORDER TO PREVENT THE RISK OF SERIOUS OR DEADLY INJURIES, WE RECOMMEND THAT PERSONS WITH MEDICAL IMPLANTS CONSULT WITH THEIR PHYSICIAN AND THE MANUFACTURER OF THE MEDICAL IMPLANT PRIOR TO OPERATING THE SAW.

SAFETY SYMBOLS

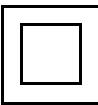
	<p>Read instruction manual and safety instructions</p>
	<p>Wear safety goggles</p>
	<p>Wear ear defenders</p>
	<p>Wear a dust mask</p>
	<p>Important! Risk of injury. Never touch the moving saw blade!</p>
	<p>Laser Radiation, Class 2 Laser: Do not stare into the beam.</p>
	<p>Protection Class II (double shielded)</p>

ELECTRICAL CONNECTIONS



WARNING: READ THESE ELECTRICAL SAFETY INSTRUCTIONS THOROUGHLY BEFORE CONNECTING THE PRODUCT TO THE MAINS SUPPLY.

Before switching the product on, make sure that the voltage of your electricity supply is the same as that indicated on the rating plate. This product is designed to operate on 230VAC 50Hz. Connecting it to any other power source may cause damage.

This product may be fitted with a non-rewireable plug. If it is necessary to change the fuse in the plug, the fuse cover must be refitted. If the fuse cover becomes lost or damaged, the plug must not be used until a suitable replacement is obtained.

If the plug has to be changed because it is not suitable for your socket, or due to damage, it should be cut off and a replacement fitted, following the wiring instructions shown below. The old plug must be disposed of safely, as insertion into a mains socket could cause an electrical hazard.

If the colours of the wires in the power cable of this product do not correspond with the markings on the terminals of your plug, proceed as follows.

- The **Blue** wire must be connected to the terminal marked **N** or coloured **Black**.
- The **Brown** wire must be connected to the terminal marked **L** or coloured **Red**

Plug must be BS1363/A approved.

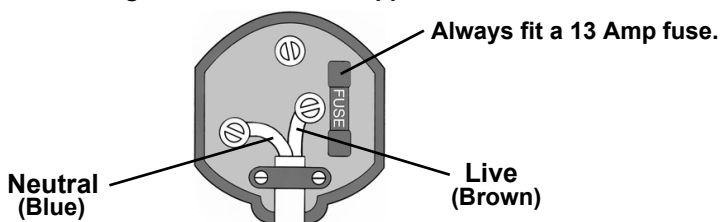

Ensure that the outer sheath of the cable is firmly held by the clamp

We strongly recommend that this machine is connected to the mains supply via a Residual Current Device (RCD)

If in any doubt, consult a qualified electrician. DO NOT attempt any repairs yourself.



This symbol indicates that this is a Class II product, and does not require an earth connection.

OVERVIEW

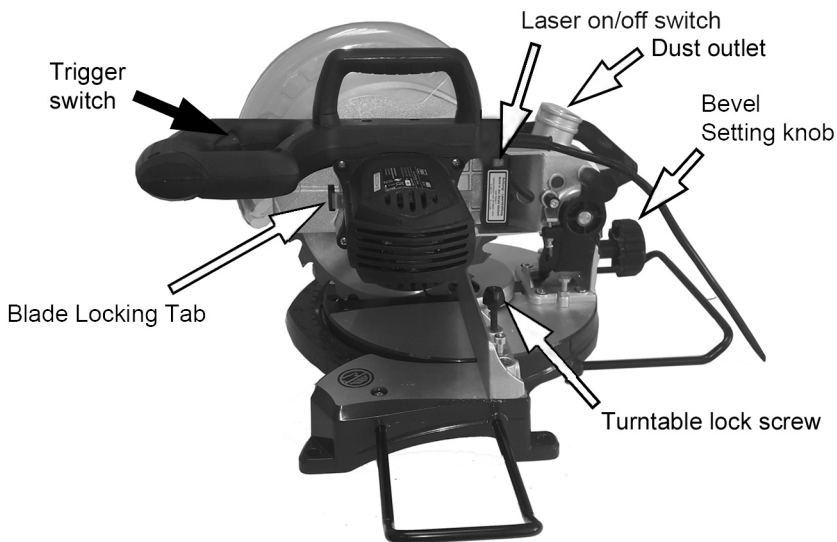
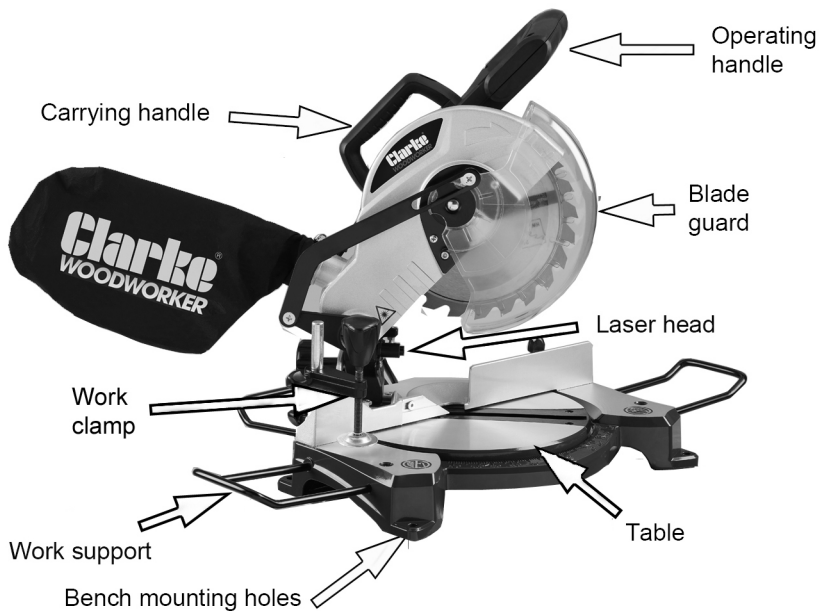

BEFORE USE

1. Remove the saw from the packing material carefully.
 - The following should be supplied. If anything is missing consult your CLARKE dealer.

1 x Cross-Cut Mitre Saw with Laser Guide	1 x Sawdust Bag
1 x Clamping Device (fitted).	1 x 6 mm Hex Key
2 x Workpiece Supports (fitted).	1 x 3 mm Hex Key
1 x Blade - 24 TCT (fitted)	2 x AAA Batteries
2 x Spare carbon brushes	1 x Instruction manual

BENCH MOUNTING

Holes are provided in all four feet to facilitate bench mounting.

- Always mount your saw firmly on a level surface to prevent movement.

The saw can also be mounted to a piece of 12.5 mm or thicker plywood which can then be clamped to your work surface.

- When mounting your saw to a piece of plywood, make sure that the mounting screws do not protrude from the bottom of the wood.

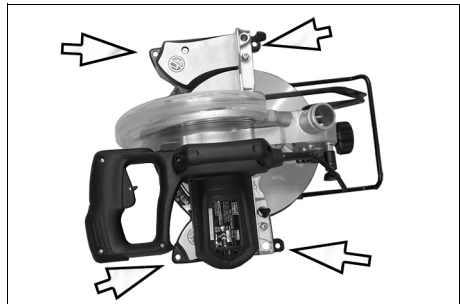

MITRE SAW STAND (NOT SUPPLIED)

You can also mount the machine to a mitre saw stand available from your local CLARKE dealer.

CUTS Mitre Saw Stand Part No 6500944.

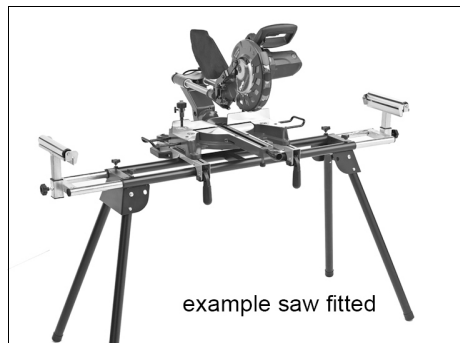

LOCKING / RELEASING THE SAW HEAD

1. Push down slightly on the operating handle and pull out the head locking pin and rotate it 90° degrees as shown so that the small pin rests on the grooves that hold the head locking pin in the unlocked position.
2. Carefully release the downward pressure on the operating handle and allow the head to rise to its full height.

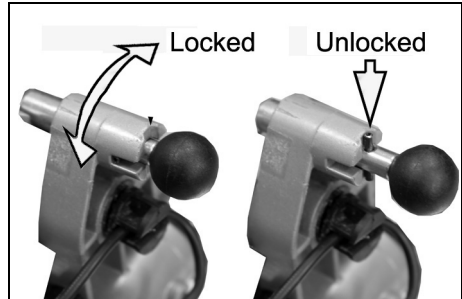
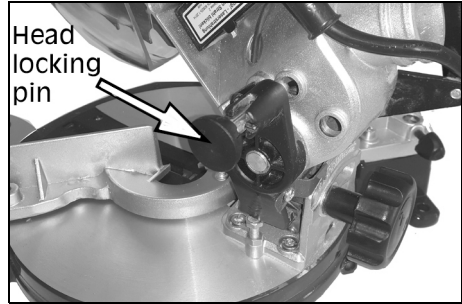

DUST EXTRACTION

This machine is provided with a dust extraction port for connection to a dust bag (supplied).

1. Squeeze together the metal ring clip on the dust bag and place it over the dust extraction port.
2. To empty the dust bag, use the zipper on the bottom of the dust bag.
3. The dust extraction port can also be connected to an extraction system using a suitable hose (not supplied)

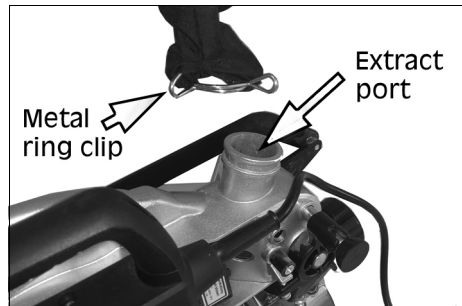

- The extraction system must be suitable for the material being worked.
- Use appropriate filters when vacuuming dust as this is dangerous to your health or carcinogenic.

WORKPIECE SUPPORTS

1. Fit the work supports to the base by sliding them into the mounting holes as far as they will go and locking with the x-headed securing screw.

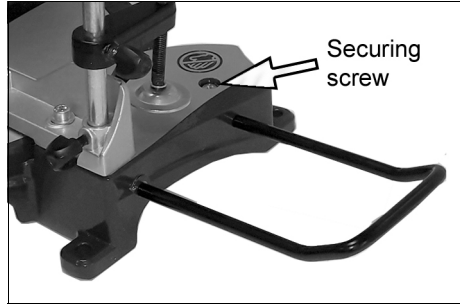

CLAMP POSITION

The clamp can be attached to either side of the saw table.

1. Insert the clamp in the hole behind the fence and secure it with the thumbscrew.
2. Set the height of the clamp to suit the workpiece using the other thumbscrew and tighten the knob to secure the work.

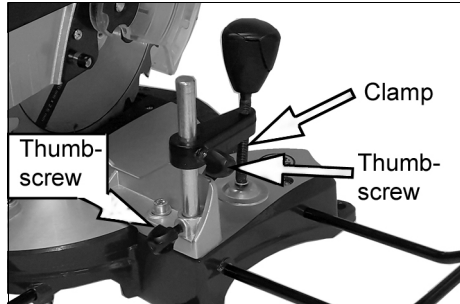

CHECK AND ADJUST THE BEVEL ANGLE

1. Loosen the bevel adjustment knob. (anticlockwise)
2. Push the saw head to vertical and tighten the knob clockwise.

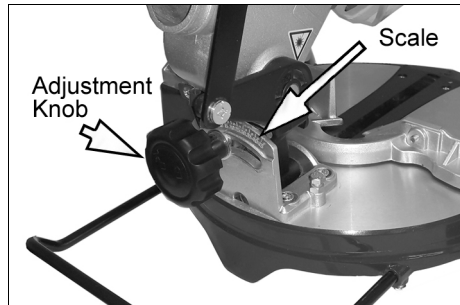

90 Degree Stop adjustment

1. Place a set square on the table surface and up against the blade.

NOTE: Keep the square clear of each tip of the blade teeth to ensure contact with the blade.

If adjustment is necessary, continue as follows:

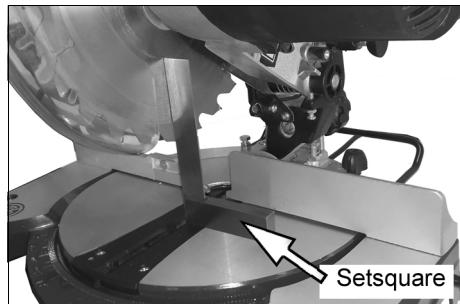

2. Loosen the lock nut and turn the 90° adjustment stop screw in or out until the blade is at 90° to the table as shown by the set square.
3. If the bevel pointer does not point to Zero on the bevel scale, loosen the screw that secures the bevel pointer and adjust the pointer as necessary.

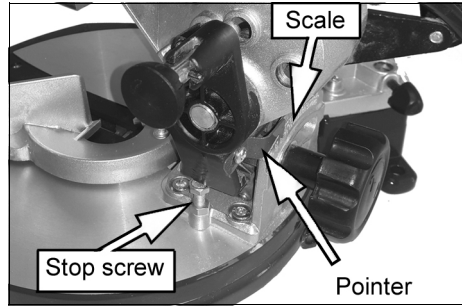

45 DEGREE STOP ADJUSTMENT

1. Loosen the bevel adjustment knob and set the saw head as far to the side as possible (this should be the 45° angle)
2. Put a 45° set square on the table and up against the blade.

NOTE: DO NOT touch the tips of the blade teeth with the square.

3. If adjustment is needed, loosen the lock nut and turn the 45° adjustment stop bolt in or out until the blade is at 45° to the table as measured with the square.
4. Adjust the bevel pointer if necessary as shown above.

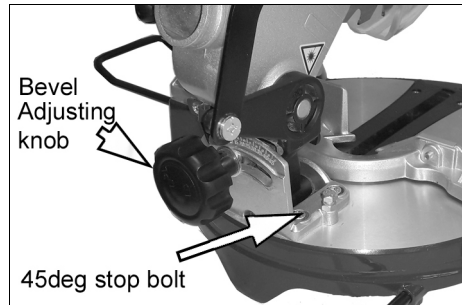

OPERATION

BODY AND HAND POSITION

Correct positioning of your body and hands when you operate the mitre saw will make cutting easier and safer.

- DO NOT put your hands near the blade.
- Clamp the workpiece tightly to the table and the fence when making cuts.
- Release the trigger switch and keep your hands in position until the blade stops.
- ALWAYS make dry runs (without power) before cuts so that you can check the path of the blade.
- DO NOT cross your hands.

VERTICAL STRAIGHT CROSS CUT

1. Check the table angles are correct.
2. Place the workpiece against the fence and secure with the clamp.
3. Press the trigger release (1) with your thumb and squeeze the trigger (2).
 - Let the motor reach full speed before cutting.
4. Lower the head slowly, allowing the blade to cut through the timber and enter the kerf plate.
5. After the cut is complete, release the trigger and allow the head to return to its upper rest position.

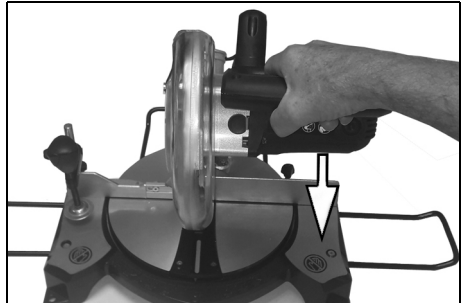
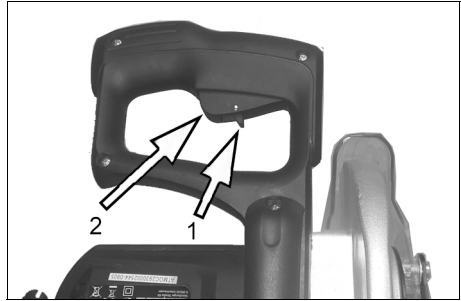

WARNING: THE BLADE WILL CONTINUE TO TURN FOR A SHORT WHILE AFTER YOU RELEASE THE TRIGGER.

PERFORMING A MITRE CUT

1. To adjust the mitre table, loosen the thumbscrew allowing the turntable to rotate

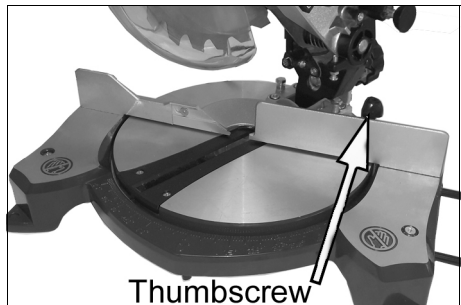

2. Turn the table to the required angle (0° to 45° left or right).
 - The angle is shown on the scale by the pointer.
3. Tighten the thumbscrew to secure the chosen setting.

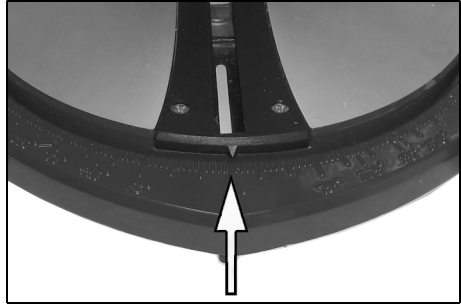

BEVEL CUTS

Bevel angles can be set from 45° left to vertical.

1. Loosen the bevel adjustment handle.
2. Set the bevel to the correct angle as shown on the scale.
3. Tighten the bevel adjustment handle.
4. Continue as for a vertical straight cross-cut.
 - For bevel cuts, the clamp must only be attached to the right side of the table.

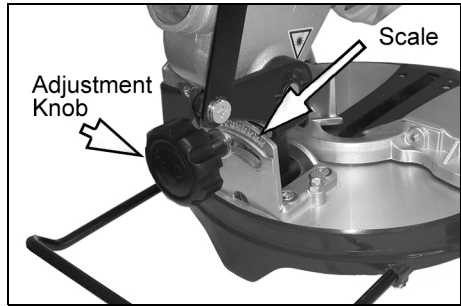

COMPOUND MITRE CUTS

A compound mitre is a cut made using a mitre angle and a bevel angle at the same time. This is the type of cut used to make frames or boxes with slanting sides.

1. Set your saw to the necessary angles.
 - Always try cuts on scrap pieces of wood to verify the settings on the saw.
2. Practice fitting the cut pieces together.



THE LASER GUIDE



CAUTION
LASER RADIATION
LASER DIODE
Wavelength 650nm Max. Output < 1mW
EN 60825-1:2014
CLASS 2 LASER PRODUCT

DO NOT STARE
INTO BEAM

Laser Radiation, Class 2 Laser: Do not stare into the beam.

TO SWITCH ON:

1. Push the laser ON/OFF switch once.
 - A laser line is projected onto the material, providing an accurate guide for the cut.

TO SWITCH OFF:

1. Push the laser ON/OFF switch again.

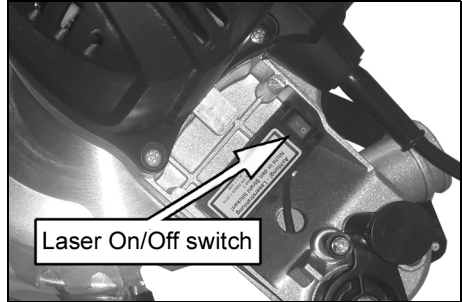

ADJUST THE LASER

If the laser does not show the correct cut line you can use the following procedure to adjust the laser.

1. Turn the laser on.
2. Loosen the cross head screws and adjust the laser by moving sideways until the laser beam hits the teeth of the saw blade.
3. Retighten the cross head screws.

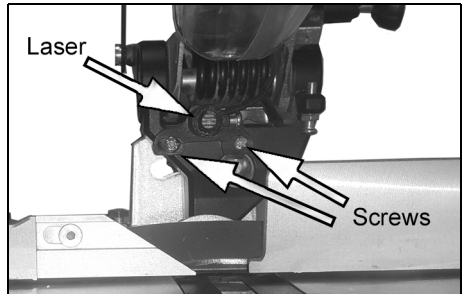

ADJUSTMENTS

CHECK AND ADJUST THE MITRE ANGLE

1. Lock the saw head in the down position see page 13.
2. Put a set square up against the left side of the fence and blade.
3. Adjust the mitre arm if necessary until the blade is perfectly square to the fence.

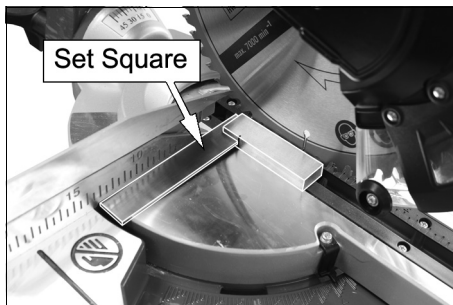

TRANSPORTING

1. Lower the head and lock it down using the head lock pin. (see page 13)
2. Lock the mitre arm with the table mitre lock.
3. Lock the bevel adjustment handle with the saw head in the vertical position to make the tool as compact as possible.

MAINTENANCE



WARNING: MAKE SURE THAT THE SAW IS SWITCHED OFF AND UNPLUGGED FROM THE MAINS SUPPLY BEFORE FITTING OR REMOVING THE BLADE.

WARNING: WEAR SAFETY GLOVES WHEN CHANGING THE SAW BLADE.

WARNING: THE BLADE MUST BE RATED TO AT LEAST 5000 RPM.

CLEANING

Your saw has been designed to operate over a long period of time with a minimum of maintenance. Continuous satisfactory operation depends upon proper care and regular cleaning.

- Regularly clean the table top.
- Regularly empty the dust collection bag.
- Keep the ventilation slots clear and regularly clean the motor housing with a soft cloth.

Avoid the use of cleaners or lubricants. In particular spray and aerosol cleaners may chemically attack the plastic lower guard.

CHANGING THE SAW BLADE

1. Insert the hex key supplied into the retaining screw.
2. Depress the blade lock and slowly rotate the retaining screw using the hex key in clockwise direction.

- The blade lock engages after no more than one rotation
- **WARNING: NEVER PUSH THE BLADE LOCK IN WHEN THE MOTOR IS RUNNING.**

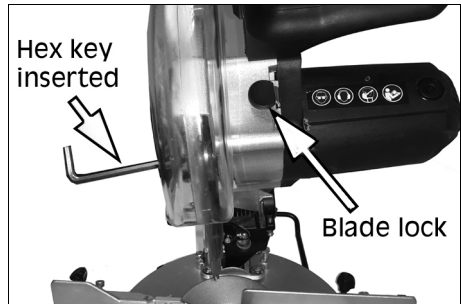

3. Remove the screw and outer blade retaining disc.
4. Remove the blade from the shaft.
5. Carefully clean the retaining screw/outer and inner disc.
6. Fit the new saw blade in reverse order.
 - Make sure that all parts are perfectly clean and the blade teeth point down at the front.
 - Every time that you change the saw blade, check to see that it spins freely in the table insert in both perpendicular and 45° angle settings.
7. Before continuing to work make sure that all guards are in good working condition.

REPLACING THE TABLE INSERT



WARNING: IF THE TABLE INSERT IS DAMAGED THERE IS A RISK OF SMALL PARTS GETTING STUCK BETWEEN TABLE INSERT AND BLADE, BLOCKING THE BLADE. REPLACE A DAMAGED TABLE INSERT IMMEDIATELY.

With a damaged table insert there is a risk of debris getting stuck between the table insert and saw blade.

1. Remove fixed stop rail from the base frame by removing the 5mm hex socket headed screw at each side.
2. Undo the four x-head screws that secure the table insert to the table.
3. Remove table insert.
4. Fit the new table insert and replace the screws.
5. Re-fit the fixed stop to the base frame.

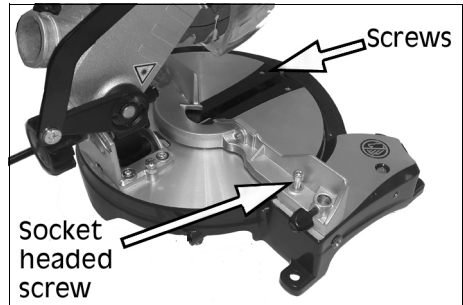

CHANGING THE CARBON BRUSHES



WARNING: MAKE SURE THAT THE SAW IS SWITCHED OFF AND UNPLUGGED FROM THE MAINS SUPPLY BEFORE INSPECTING OR CHANGING THE CARBON BRUSHES.

After extensive use, the carbon brushes will become worn and should be checked if the motor seems to be lacking power. Replacements are available from your CLARKE dealer.

1. Unscrew the carbon brush cover using a screwdriver.
2. The carbon brush should spring out.
 - If the carbon is worn to a length of 6mm or less, or if the spring or contact wire is burned or damaged, replace both brushes.
3. Replace each carbon brush cover, taking care not to cross thread it.

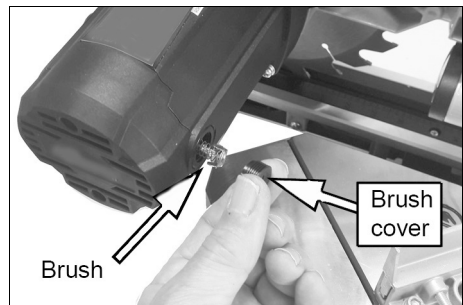

SPECIFICATIONS

Model Number	CMS210B
Part Number	6461520
Rated Voltage	230 V AC @ 50Hz
Input Wattage	1500 W
Ingress protection	IP X0
Blade Diameter	210 mm
Blade bore	30 mm
Max. blade thickness	2.6 mm
Kerf	3.0mm
Max. no load machine speed	5000 rpm
Max. cross-cut capacity at 90°	120 mm x 60 mm
Max. Mitre cut 45°	80 mm x 60 mm
Max Bevel cut 2 x 45°	80 mm x 35 mm
Max compound cut	80 mm x 35 mm
Max Bevel Angle	0-45° to the left
Sound pressure (L_{pA})	99.6 dB (A)
Guaranteed Sound power (L_{WA})	112.6 dB (A)
Uncertainty Factor (K)	3
Dimensions (Length x Width x Height) - max	615 x 650 x 460 mm
Weight	7.6 kg
Laser class	2
Laser power	<1mW
Laser wavelength	650nm
Degree of protection	Class 3
Battery type for laser	AAA x 2



WARNING: THE NOISE EMISSIONS DURING THE ACTUAL USE OF THE MITRE SAW MAY DIFFER FROM THE ABOVE-MENTIONED VALUES DEPENDING ON THE TYPE OF WORKPIECE BEING CUT.

COMPONENT PARTS

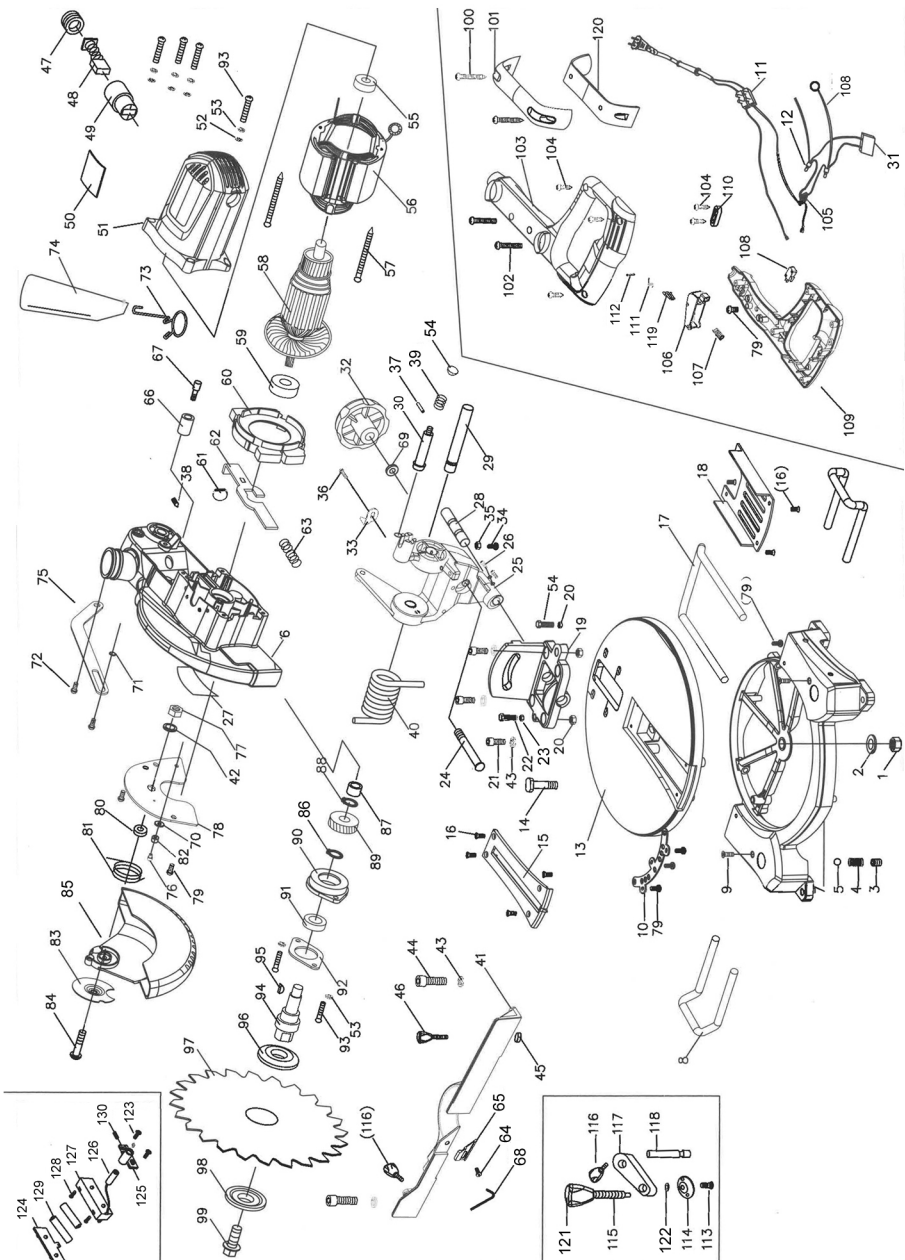

COMPONENT PARTS LIST

No	Description
1	Nut
2	Washer
3	Grubscrew
4	Spring
5	Steel Ball
6	Machine body
7	Base Frame
8	Side Work support
9	Screw
10	Swing plate
11	Power cable assembly
12	Connector
13	Turntable
14	Bolt
15	Kerf plate
16	Screw
17	Front work support
18	Cover plate
19	Pivot block
20	Nut
21	Socket head bolt
22	Hex head Bolt
23	Washer
24	Pivot bolt
25	Pivot Yoke
26	Screw
27	Label
28	Pivot Axle
29	Pivot Axle
30	Arm locking peg
31	Switch

No	Description
32	Bevel adjustment knob
33	Pointer
34	Bolt
35	Nut
36	Screw
37	Roll Pin
38	Grub screw
39	Spring
40	Spring
41	Fence
42	Washer
43	Washer
44	Socket head bolt
45	Spacer
46	Locking knob
47	Brush cover
48	Carbon brush assembly
49	Brush holder
50	Label
51	Motor housing
52	Flat Washer
53	Spring Washer
54	End cap
55	Bearing
56	Motor Stator
57	Tie screws
58	Motor Rotor assembly
59	Bearing
60	Motor end housing
61	Thumb pad
62	Blade locking tab

No	Description
63	Spring
64	Toe piece
65	Socket head screw
66	Sleeve
67	Screw
68	Hex key
69	Washer
70	Washer
71	Washer
72	Pan headed screw
73	Support clasp
74	Dust bag
75	Actuating arm
76	Screw
77	Nut
78	Backing plate
79	Screw
80	Bush
81	Guard Spring
82	Spacer
83	Gauge Retaining flange
84	Gauge Retaining bolt
85	Moving guard
86	Circlip
87	Bush
88	Circlip
89	Spur gear
90	Bearing housing
91	Bearing
92	Bearing retaining plate
93	Screw
94	Main spindle
95	Woodruffe key
96	Inner retaining disc

No	Description
97	Blade
98	Outer retaining disc
99	Blade securing bolt
100	Screw
101	Carrying Handle
102	Screw
103	Handle body (right)
104	Screw
105	Connector
106	Trigger
107	Spring
108	Wiring
109	Handle body (left)
110	Cable clamp
111	Open Spring
112	Hinge Pin
113	Screw
114	Clamp Pad
115	Clamp Shank
116	Clamp locking thumbscrew
117	Clamp Arm
118	Clamp Pivot Rod
119	Safety pawl
120	Carry handle grip
121	Clamp knob
122	Washer
123	Screw
124	Backing plate
125	Housing
126	Laser Light Assembly
127	Mounting body
128	Screw
129	Sleeve
130	Screw

ENVIRONMENTAL PROTECTION



Recycle unwanted materials instead of disposing of them as waste. All tools, accessories and packaging should be sorted and taken to a recycling centre for disposal in a manner compatible with the environment.

By purchasing this product, the customer is taking on the obligation to deal with its safe disposal in accordance with the Waste Electrical and Electronic Equipment (WEEE).

In effect, this means that this product must not be disposed of with general household waste. It must be disposed of according to the laws governing Waste Electrical and Electronic Equipment (WEEE) at a recognised disposal facility. If disposing of this product or any damaged components, do not dispose of with general waste. This product contains valuable raw materials. Metal products should be taken to your local civic amenity site for recycling of metal products.

DECLARATIONS OF CONFORMITY



Clarke[®]
INTERNATIONAL
Fitzwilliam Hall, Fitzwilliam Place, Dublin 2

DECLARATION OF CONFORMITY

This is an important document and should be retained.

We hereby declare that this product(s) complies with the following directive(s):

2006/42/EC Machinery Directive
2014/30/EU Electromagnetic Compatibility Directive
2011/65/EU Restriction of Hazardous substances (Amendment EU 2015/863)

The following standards have been applied to the product(s):

EN 62841-1:2015, EN 62841-3-9:2015(A1):2017, EN 55014-2:2015,
EN 61000-3-2:2014, EN 61000-3-3:2013, EN 62321-1:2013, EN 62321-2:2014, EN 62321-3-1:2014,
EN 62321-5:2014, EN 62321-7-1:2015, EN 62321-7-2:2017, EN 62321-6:2015, EN 62321-8:2017.

The technical documentation required to demonstrate that the product(s) meet(s) the requirement(s) of the aforementioned directive(s) has been compiled and is available for inspection by the relevant enforcement authorities.

The CE mark was first applied in: 2021

Product Description: 210mm Mitre Saw
Model number(s): CMS210B
Serial / batch Number: N/A
Date of issue: 18/11/2021

Signed:

J.A. Clarke
Director

CMS210B CE Clarke DOC 111821

Page 1 of 1



Clarke[®]
INTERNATIONAL
Hennell Street, Epping, Essex CM15 4LG

DECLARATION OF CONFORMITY

This is an important document and should be retained.

We hereby declare that this product(s) complies with the following statutory requirement(s):

Supply of Machinery (Safety) Regulations 2008
Electromagnetic Compatibility Regulations 2016
The Restriction of the Use of Certain Hazardous Substances in Electrical and Electronic Equipment Regulations 2012.

The following standards have been applied to the product(s):

EN 62841-1:2015, EN 62841-3-9:2015(A1):2017, EN 55014-2:2015,
EN 61000-3-2:2014, EN 61000-3-3:2013, EN 62321-1:2013, EN 62321-2:2014, EN 62321-3-1:2014,
EN 62321-5:2014, EN 62321-7-1:2015, EN 62321-7-2:2017, EN 62321-6:2015, EN 62321-8:2017.

The technical documentation required to demonstrate that the product(s) meet(s) the requirement(s) of the aforementioned legislation has been compiled and is available for inspection by the relevant enforcement authorities.

The UKCA mark was first applied in: 2021

Product Description: 210mm Mitre Saw
Model number(s): CMS210B
Serial / batch Number: N/A
Date of issue: 18/11/2021

Signed:

J.A. Clarke
Director

CMS210B UKCA, Clarke DOC 111821

Page 1 of 2

A SELECTION FROM THE VAST RANGE OF

Clarke®

QUALITY PRODUCTS



AIR COMPRESSORS

From DIY to industrial, Plus air tools, spray guns and accessories.

GENERATORS

Prime duty or emergency standby for business, home and leisure.

POWER WASHERS

Hot and cold, electric and engine driven - we have what you need

WELDERS

Mig, Arc, Tig and Spot. From DIY to auto/industrial.

METALWORKING

Drills, grinders and saws for DIY and professional use.

WOODWORKING

Saws, sanders, lathes, mortisers and dust extraction.

HYDRAULICS

Cranes, body repair kits, transmission jacks for all types of workshop use.

WATER PUMPS

Submersible, electric and engine driven for DIY, agriculture and industry.

POWER TOOLS

Angle grinders, cordless drill sets, saws and sanders.

STARTERS/CHARGERS

All sizes for car and commercial use.

PARTS & SERVICE:

0208 988 7400

Parts Enquiries

Parts@clarkeinternational.com

Servicing & Technical Enquiries

Service@clarkeinternational.com

SALES: UK 01992 565333 or Export 00 44 (0)1992 565335

Clarke INTERNATIONAL Hemnall Street, Epping, Essex CM16 4LG
www.clarkeinternational.com